

Industrial UPS 10-30KVA

REL3111-IND

Series



GREEN
ENERGY SAVING
ENVIRONMENTAL PROTECTION

REL3111-IND Series

Industrial UPS
10-30KVA (1Ph in & 1Ph out)

Industrial
Processes



Product snapshot:

Model: 10-30KVA
Nominal voltage: 120/208/220 VAC
Nominal frequency: 50/60Hz
Output Power factor: 0.8



High-reliability Industrial Grade Design:

The REL3111-IND system is composed of power special-purpose UPS, DBW bypass regulator cabinet, PDU series feeder cabinet. Reliability REL3111-IND system is developed specifically for mission-critical facilities eg. power plants, substations, power distribution products are designed with online double conversion, zero conversion function. Main applications including electric power long distance, RTU, power carrier wave, power monitoring and so on. When the utility power is normal, single phase 110V After isolation, rectification and filtering through the inverter to provide a stable power supply to the load; if the input AC power is abnormal or power failure, the backup power system by the DC screen provide power supply through non-return diode inverter. When the DC screen occurs voltage shortage or power break, the static switch transfer to bypass for power supply; When the electricity is restored, the inverter automatically switches to utility power and provide power supply under inverter mode. If the inverter overload or fault and transfer power supply under bypass mode, also give a warning signal at the same time.

Security for key equipment continuing to run, we offer all serial of uninterruptible AC power system and relative distribution and complete power distribution products, including individual products, integrated system, personal network security, IT, medical systems, provide good power protection and stable operation for manufacturing.

Application:

Petroleum, chemical industry, gas and power station...

Key Features:

- Adopt full digital control technology.
- Intelligent detection and monitoring function.
- Digital control and static switch zero switching.
- Input/output full isolation
- DC UPS isolated with utility power completely.
- Cubicle design with power standard.
- Multifunctional protection for overvoltage, low voltage,
- Overcurrent, short circuit and so on.
- Large-screen LCD monitor Chinese and English operation interface.
- Ultralong 256 event records, user-friendly analysis and management to the situation of power supply.
- Static bypass has a strong anti-overload capacity.

Control System

Adopt microprocessor bus control technology and ensure the real-time control of rectifier, inverter, static switch as well as coordination of each power part, characterized by increased control of aging, higher reliability, enhance the efficiency of complete UPS system and the output technical parameters are better than that of the general capacity of equipment.

Rectifier

4 pulse fully controlled bridge (4 SCR) composed of rectifier, its function is input AC 120V rectified for DC 120V or so. Control features for the "slope" start, that is to say the output voltage of rectifier within 10 seconds from the 0V to 120V and no impact on the power grid.

Inverter

4 IGBT high power tubes of SPWM (sinusoidal pulse width modulation) composed of all Control bridge. It's function is to transform DC voltage for standard sinusoidal AC voltage by the special (Δ/Y) zero phase shift zigzag type isolation transformer and become AC110V as load required; In addition, the transformer can eliminate from such as computer(non-linear load) reflect three times harmonic current capacity. Control feature adopt a "slow-down gate voltage" protection technology and greatly reduce the disturbance shutoff of inverter (inverter and static switch change each other), and increase the over-load capacity of complete UPS system, short circuit and anti-overload are better than general UPS, especially it's anti-short-circuit capacity is unmatched by similar devices.

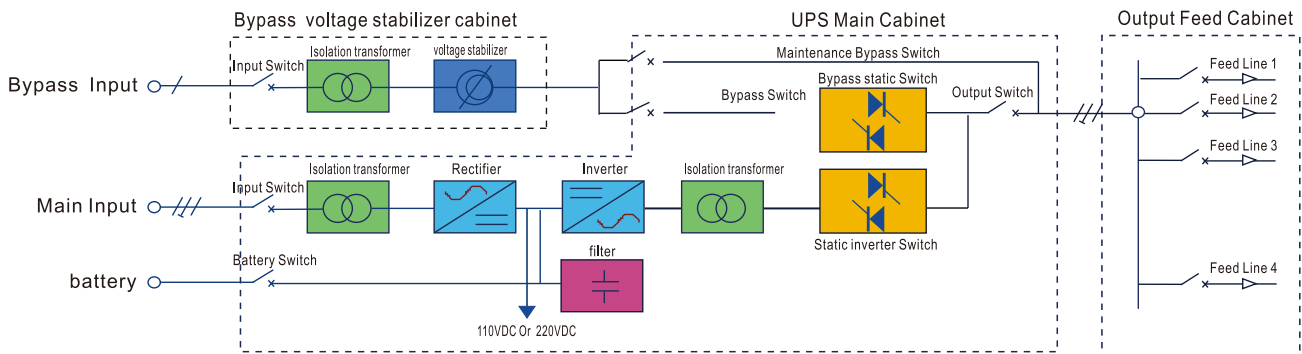

Principle Diagram

Static Switch:

Not sync automatically switch:

- When the bypass of UPS and inverter are not synchronized, system can automatically implement not sync switch, such as city electricity surge pulse width <5ms can ensure no power cutoff.
- When the bypass exceed limit, UPS will detect the bypass every 20ms, as long as the phase angle difference of bypass and inverter come back to the normal range, not synchronized bypass switch can be realized.

Intelligent Monitoring:

Via RS232/RS485, passive contact and power transmitter signal to transfer working status of UPS and real-time data to the DCS system, finally realize intelligent monitoring.

Unique Option:

- SNMP Card
- AS400 Card
- Signal Transmitter
- Bypass Isolation and Voltage Regulation
- Increase feeder circuit (standard for 8 loops)
- The appearance of special models (Standard dimension:800x600x2260mm)

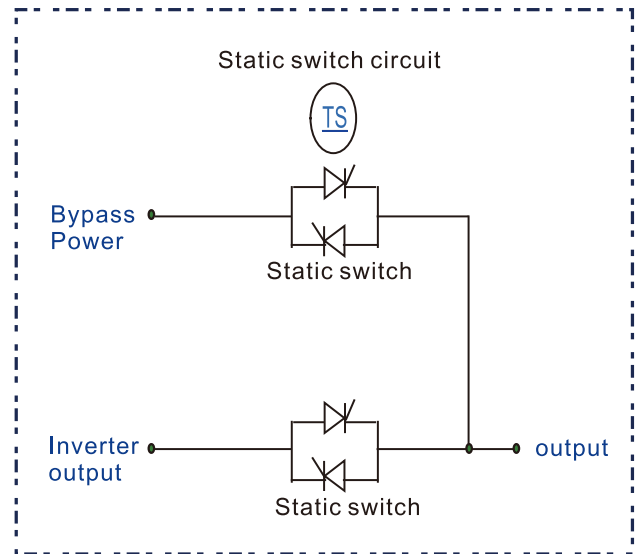

Optional Bypass Cabinet :

Isolation transformer and Bypass voltage regulator

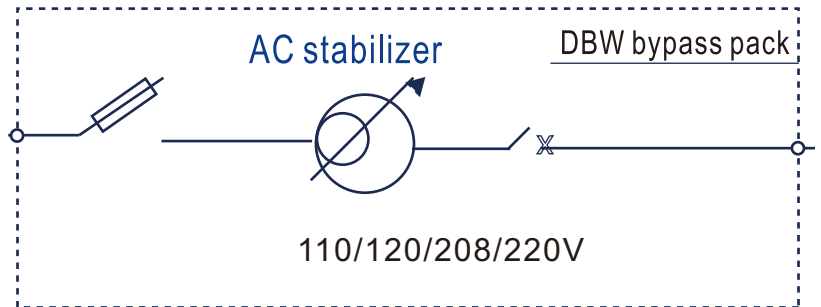
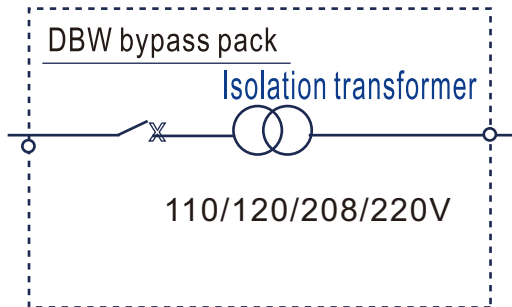

REL3111-IND Technical Specifications

| REL3111-IND 10-30KVA | | | | | | | |
|----------------------------------|--|-------------|-------------|-------|-----|-----|-----|
| Model | 10KVA | 15KVA | 20KVA | 30KVA | | | |
| Capacity | 8KW | 12KW | 16KW | 24KW | | | |
| Input | | | | | | | |
| Rated voltage | 110/120/208/220 Vac three-phase | | | | | | |
| Voltage range | ±20% | | | | | | |
| Frequency range | 50/60HZ±5% | | | | | | |
| Power factor | ≥0.8 | | | | | | |
| Current harmonic distortion | <5%with harmonic filter | | | | | | |
| Soft Start | 0-100% in10" | | | | | | |
| Bypass Input | | | | | | | |
| Rated voltage | 110/120/208/220 Vac single-phase | | | | | | |
| Permitted voltage range | ±15%(selectable from ±10% to ±25% from front panel) | | | | | | |
| Rated frequency | 50/60Hz | | | | | | |
| Permitted frequency range | ±2%(selectable from ±1% to ±5% from front panel) | | | | | | |
| Standard features | BackFeed portection; split bypass line | | | | | | |
| Batteries | | | | | | | |
| Type | Maintenance-free lead-acid VRLA AGM / GEL;NICd | | | | | | |
| Maximum recharge current(A) | 0.2 X C10 | | | | | | |
| DC Voltage | 110VDC | | | | | | |
| AC ripple voltage | <1% | | | | | | |
| Inverter output | | | | | | | |
| Number of phases | 1 | | | | | | |
| Rated voltage(V) | 110/120/208/220 Vac single-phase | | | | | | |
| Regulation of the output voltage | 100~125Vac phase/neutral(from control panel) | | | | | | |
| Crest factor(Ipeak/Irms) | 3:1 | | | | | | |
| Static stability | ±1% | | | | | | |
| Dynamic stability | ±5% | | | | | | |
| Frequency | 50/60Hz configurable | | | | | | |
| Overload | 110% 125% 150% of the rated current for 5h/10'/1' | | | | | | |
| Frequency stability | ±0.05% on mains failure | | | | | | |
| System | | | | | | | |
| Remote signaling | Volt free contacts | | | | | | |
| Remote controls | EPO and Bypass | | | | | | |
| Communication | RS232 + romote contacts | | | | | | |
| Operation temperature | 0°C / + 40°C | | | | | | |
| Relative humidity | <95% non condensing | | | | | | |
| Colour | Light grey (RAL 7035) | | | | | | |
| Noise | 54dBA at 1m | 60dBA at 1m | 65dBA at 1m | | | | |
| Protection degree | IP42 | | | | | | |
| Efficiency Smart Mode | up to 98% | | | | | | |
| Compliance | Safety:EN 62040-1-1(Directive 2006/95/EC); EMC:6200-2(Directive 2004/108/EC) | | | | | | |
| Weight(KG)N.W | 200 | 220 | 230 | 260 | 290 | 340 | 440 |

STANDARD: Conform to GB/IEC regulation: EMC:GB7260.2/IEC62040-2 -GB/17626.2~5/IEC61000-4-2~5 SAFETY:GB4943

Note: Product specifications are subject to change without further notice.

